

BW30K  
30KW

---

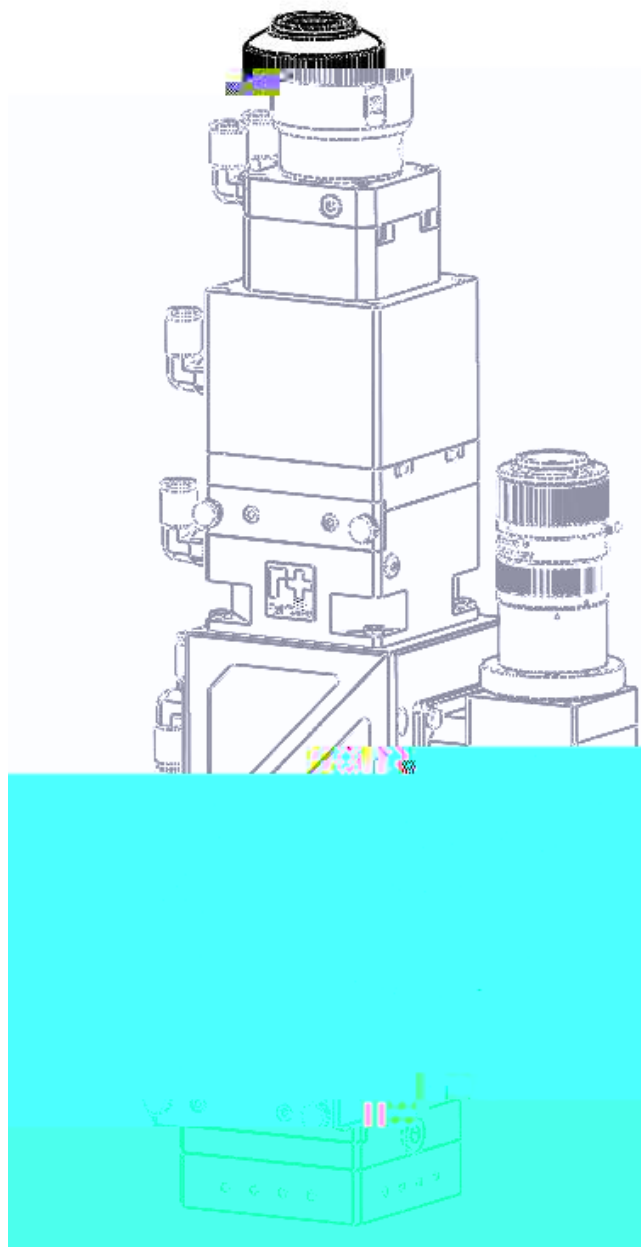

**Empower** 嘉强

Hotline: 400-670-1510

Email: sales@empower.cn

Add: 上海市 松江区 东宝路 8 号



---

01

2025. 08

---

- 

-

---

●

1)

2)

3)

4)

5)

●

1)

2)

3)

●

●

●

1)

2)

3)





g 0g

---

---

1.3

	BV80K
	1064nm
	30KW
	LOE3.1 ( ), QBH/Q+
	45mm
	150mm
	F 250mm/ 300mm/ 350mm/ 400mm
	Ø50* 2mm
	C/CS
	Ø6mm
	Ø8mm
	5.5kg



---

1.5

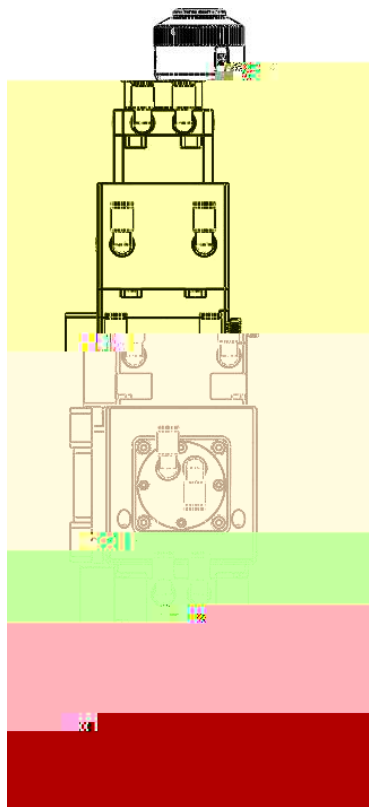

BV8CK

1.6

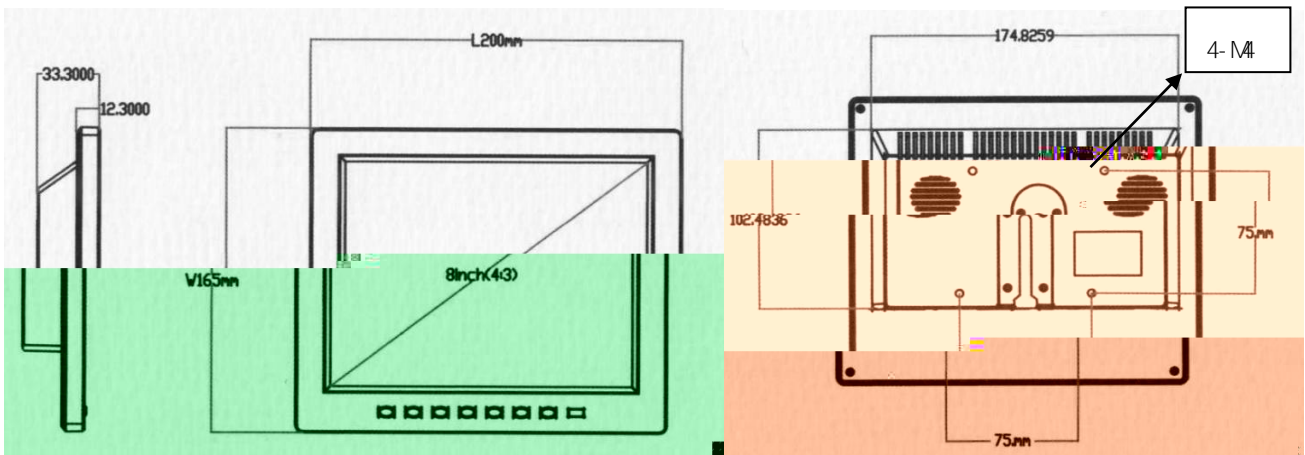
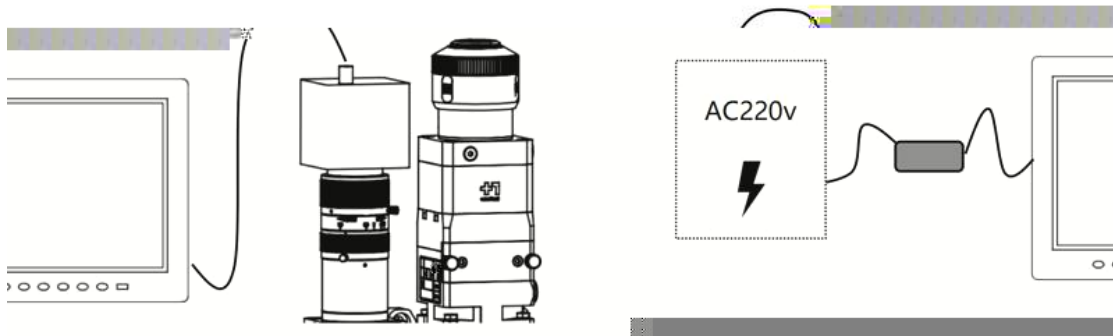

---

1.7

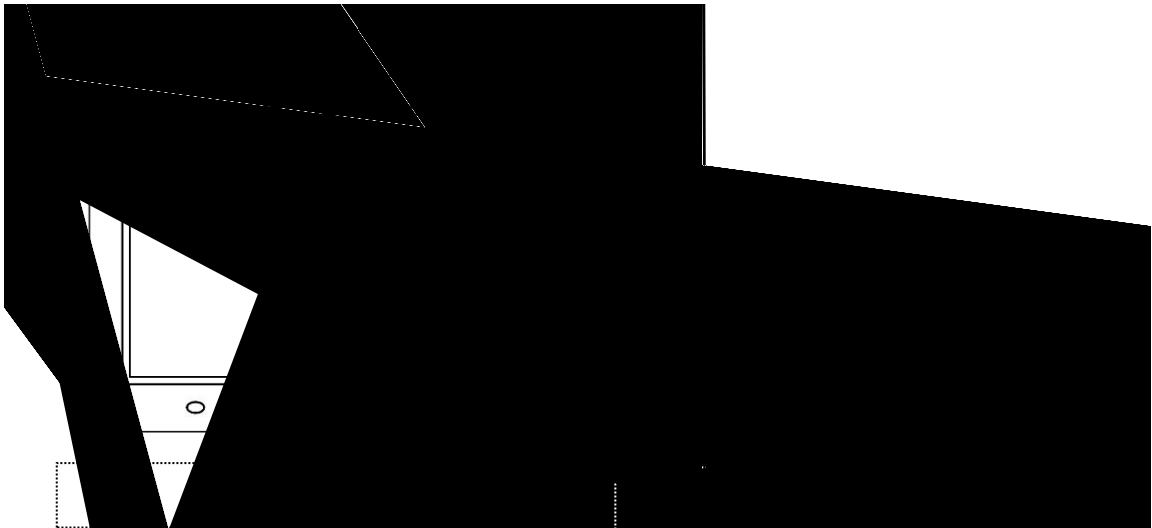
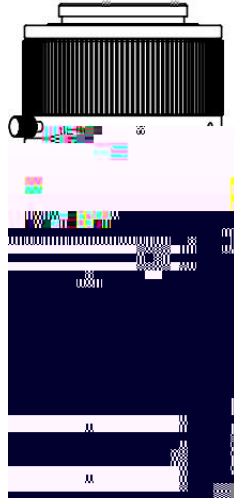

---

1.8

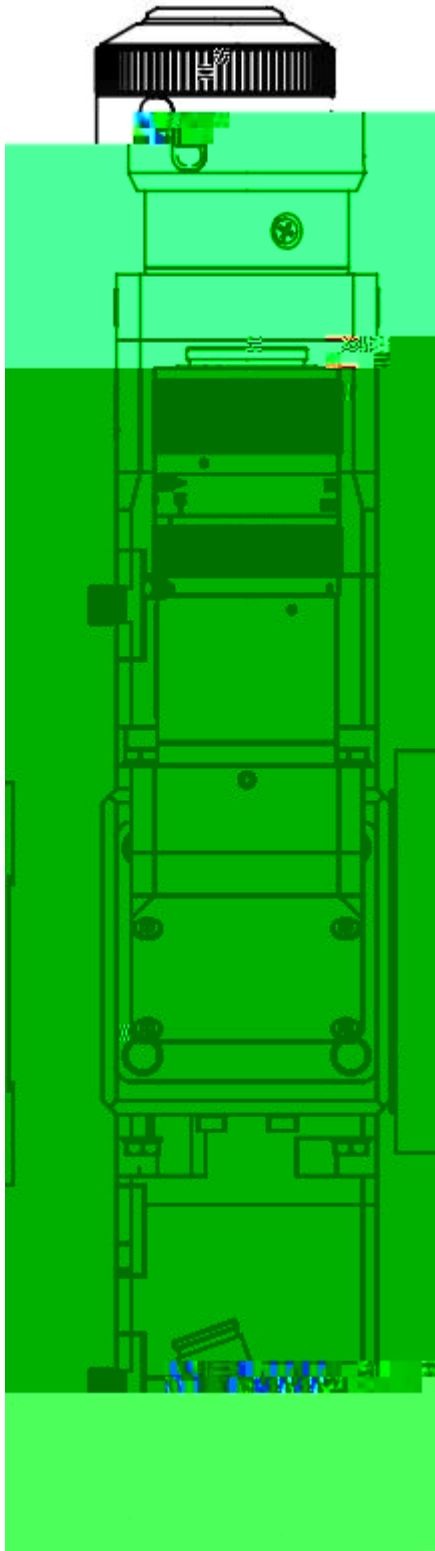

2.

2.1

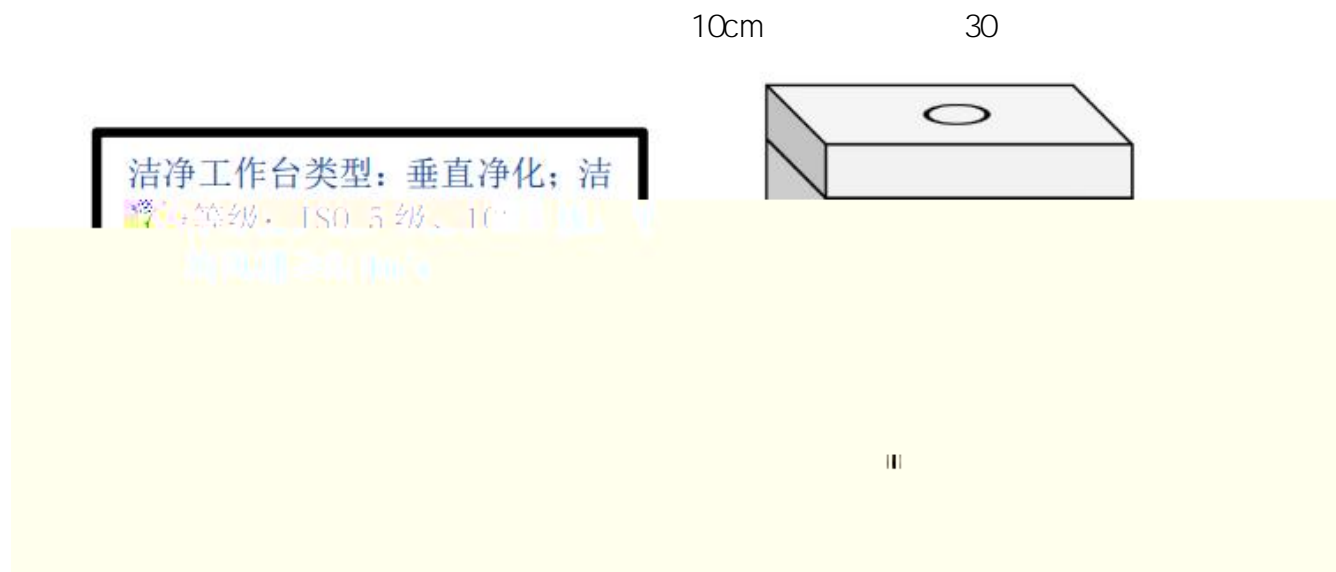

2.2

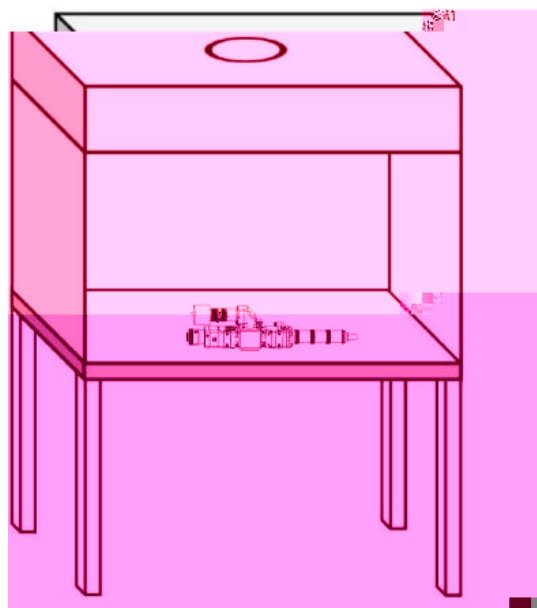

2.3

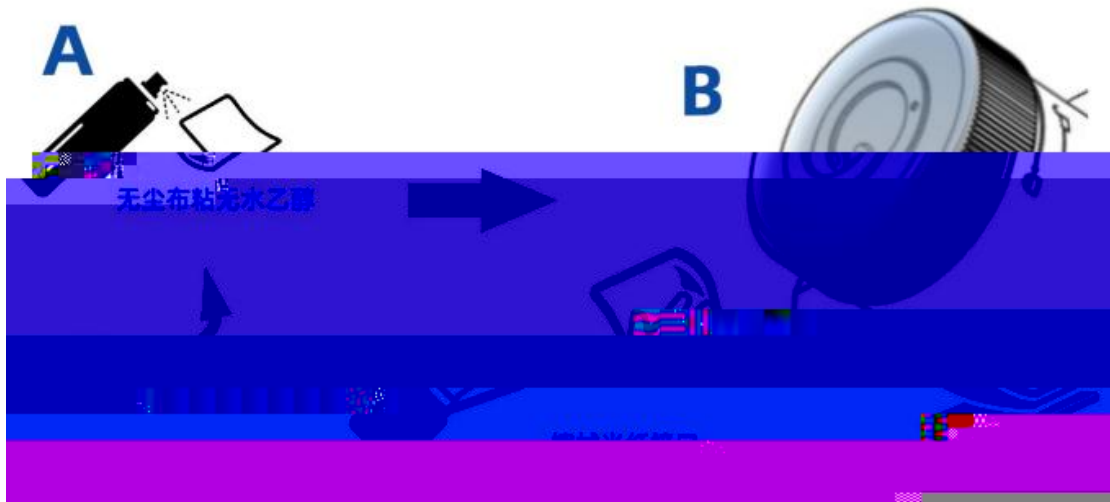

2.4



! u  
2.5  
E O

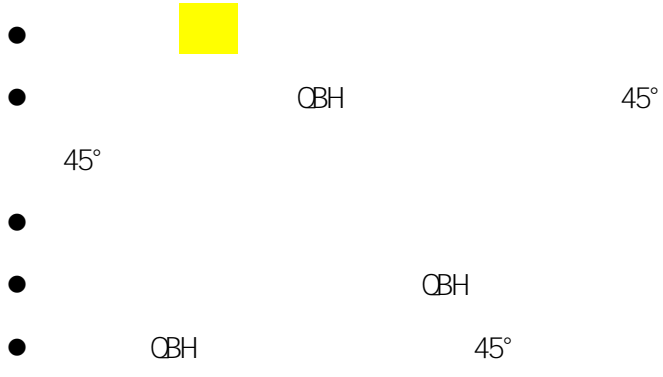

---

2.7

Mx20

/

---

2. 8

BW8OK

/

/ /

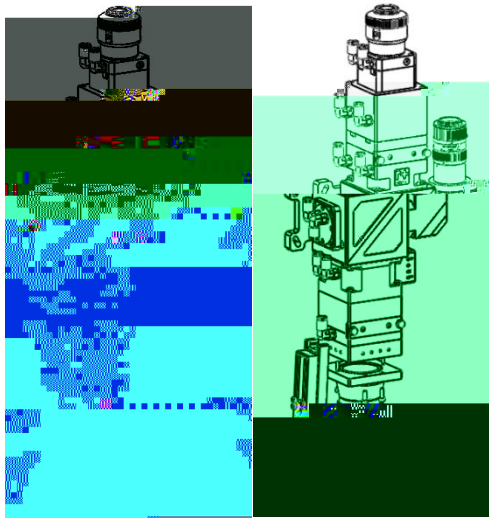

3.  
3.1



- 1.
- 2.
- 3.
- 4.
- 5.
- 6.
- 7.
- 8.



3. 2



- 1.
- 2.
- 3.
- 4.
- 5.
- 6.
- 7.
- 8.



4.  
4.1  
1

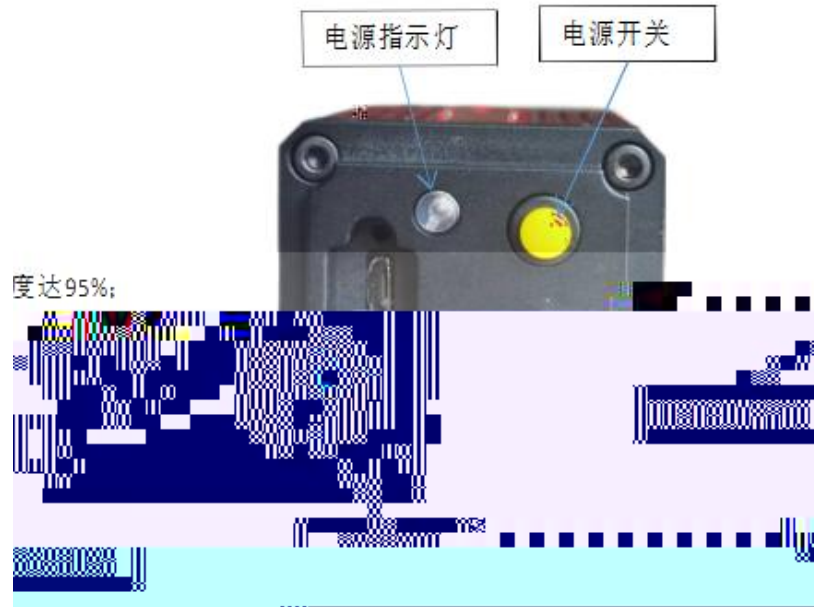

2

A      sdk      McaVi si on Camera Pl atformSetup(2.1.10 . /tip      j





“ ”

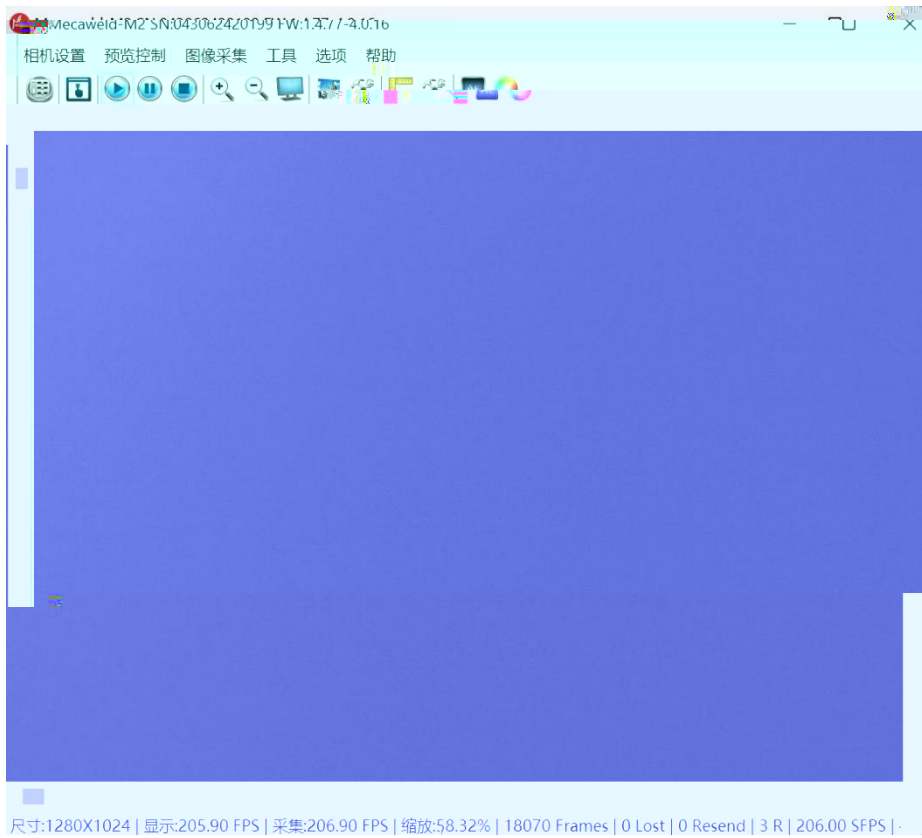

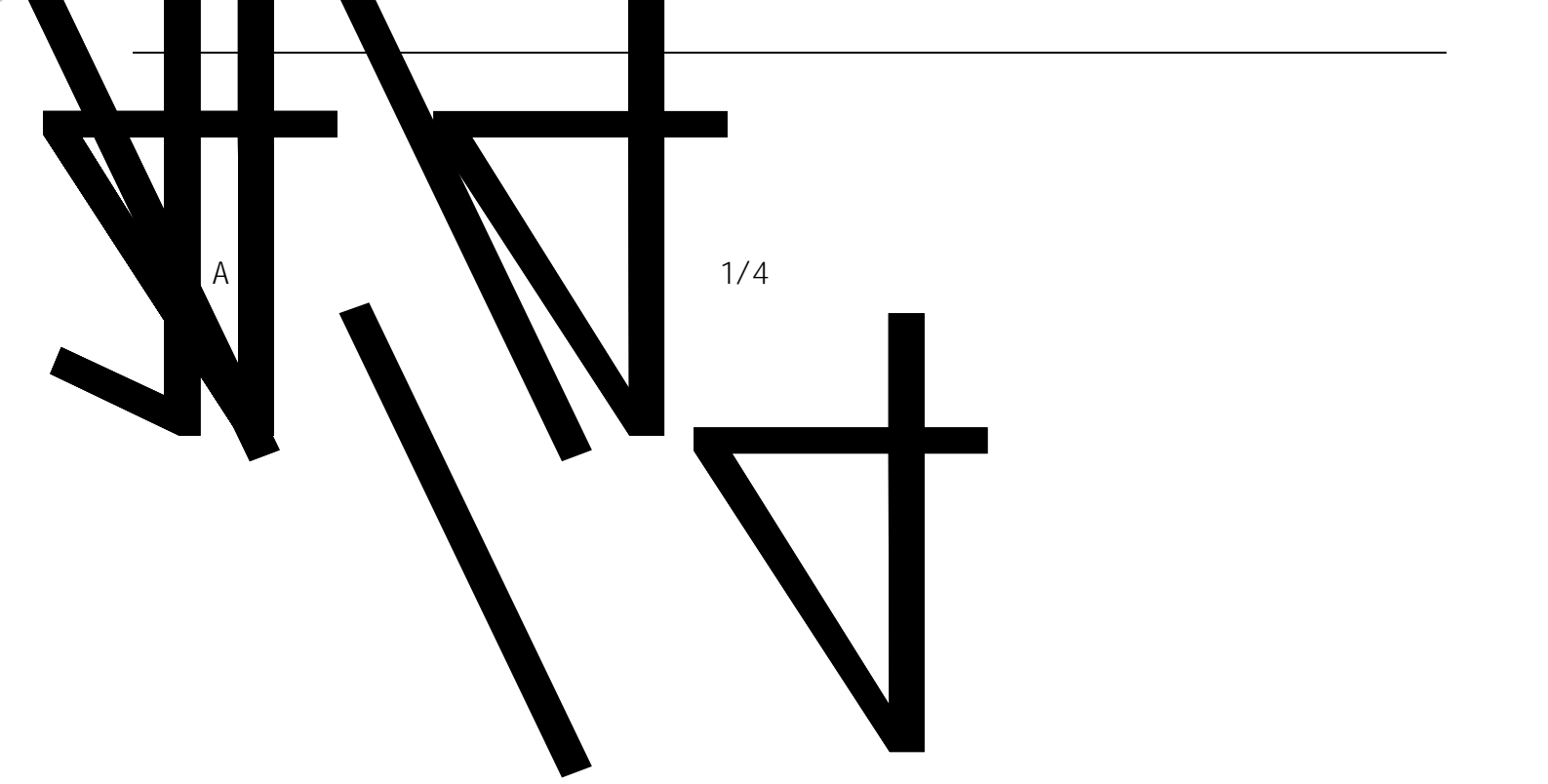

A

1/4

---

通常情况下请按照相机的默认参数相机即可正常工作

如果不小心调乱了参数导致相机不能正常工作，  
认设定参数！

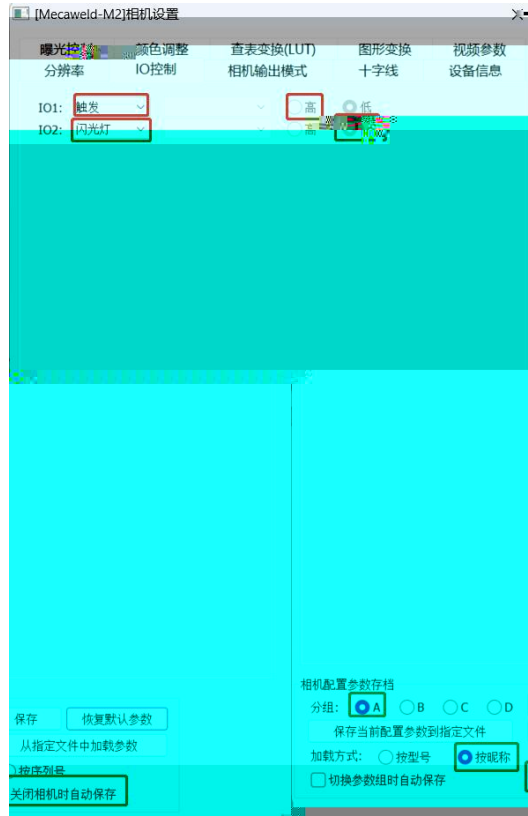

“ ”

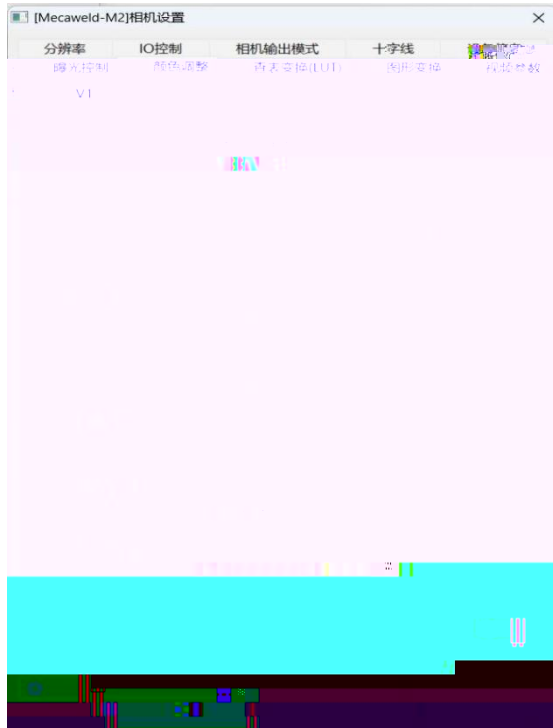

---

" LUT "

"

" " " "

“ Mecavel d” logo

“ ” 180°

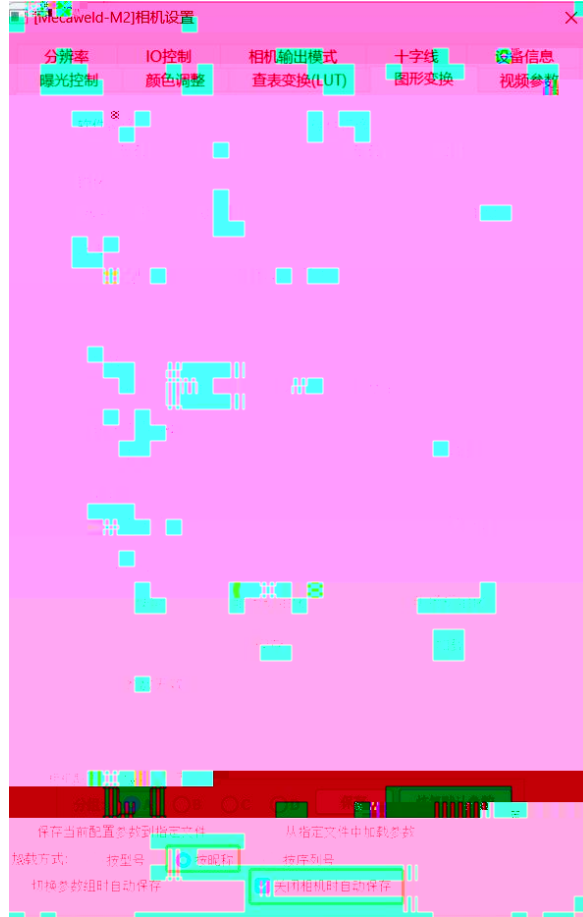

"

"

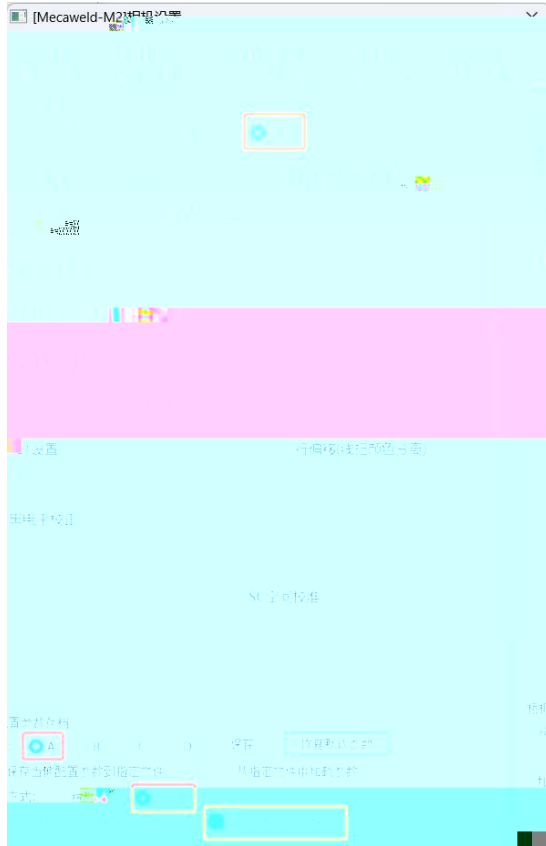

"

"

"

"

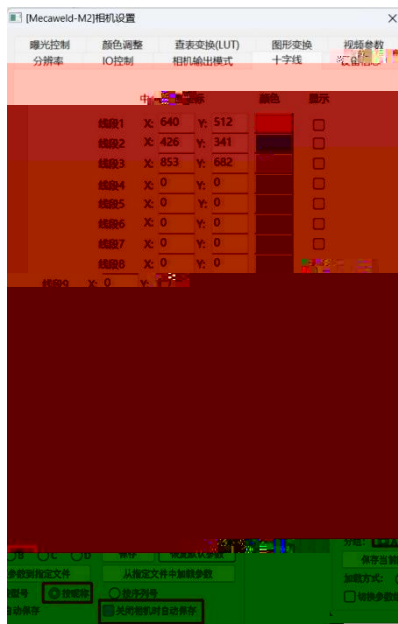







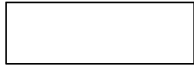
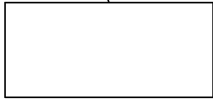
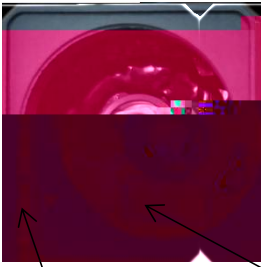

---

4. 2



QBH , 0°

	L1(mm)	L2(mm)
F100	172. 9	383. 9
F150	222. 2	433. 2



嘉强 (上海) 智能科技有限公司

地址: 上海浦东新区东育路8号

电话: 400-670-1510

邮箱: sales@empower.cn

网址: www.empower.cn