

j ~ ê £ F1 M j

---

x ñB\$ > -

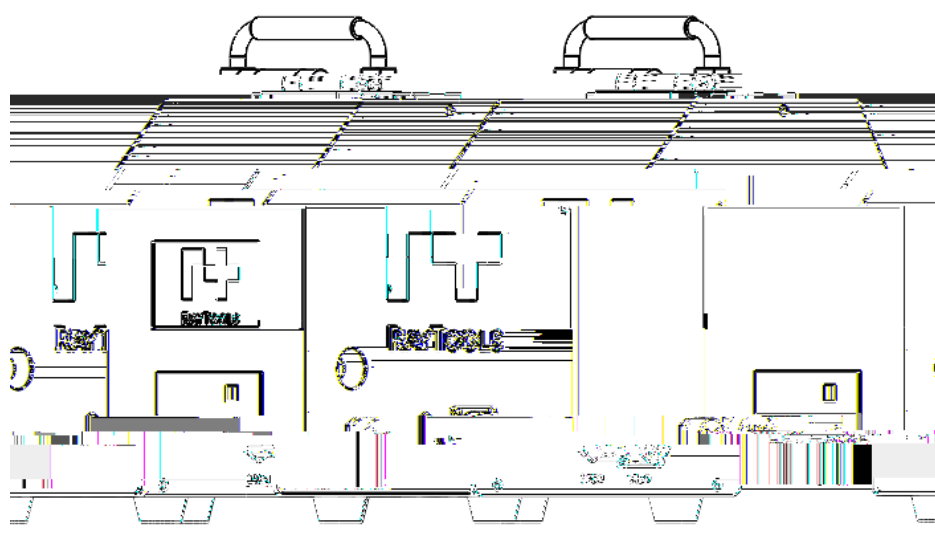

**Empower** 青强  
Empower 青强

Hotline: 400-670-1510

Email: sales@empower.cn

Add: 上海市松江区东宝路8号



1 ~ , |

\j Ö 9 Ô#q+e È = 1~, '0; ç ¼ ý ÇE 6 ,8\$ êDÛ T ã F!«

Ñ ¼C] \Aî 7, '+X g È^-X65 ¼Eµ Û ê ^ ÈG- òN«L5B+ ¼\*6@ \ 1~, | Ä

Lb!'@ +e Ö Ö@ V+eG 6 6 J ,8\$ UGý, ' T ã ¼8\$ -, ' f + Ä

Ä =?±@ " V+eG 6 Ä

Ä =?± X%ž\$-, ' )ß ³; ÇE x

Ä 0^- : ç( 5 5H, ' { ‡ ¼ ÇE Ô = Ä

Ä X 1>õ5\$ \Aî 7 } 7 Ý p 9+e\$Ä Ä

Ä =^-X & £ 1+e\$Ä Ä

Ä =?± ^+X.d +e56 ¼ Z ? Ä Ö@ =8ÿ, ' Ö d x

Ä =?± °+e565P5 XDÛ : x

Ä ^+X 98ÿ -5\$ Ô, 'Aî 7 È ) " •Aî 7F >| ú & \*6 ¼ \$ ' Ä

Ä ': Ö & , M1ÑH ŽG 6 V+e ÈB' /@ .à

Lb!' M. ¼"D f, ' T ã Ö h • M. ¼ 9 ã"D f 6 J T ú ê f • ç Ä

ÄÄ ^ dG F /ë' M.

Ä ^+XF2 f, 'FJNpAî 7 ° M. ¼ 9 ã"D f p ÇE ¼ ^ h j íC Ä

Ä ² ÌFJNp3+5 = 8F2 È ^+X ^ h Ô>õ5ž Ä

Ô - »5Y²¼1D»6ZÖÜD»2UöpÈR²5EÄ



Lb!'%đ y T ã-l-¼,þ6Ô Èlb!' šN# T ã \?ù Ö: Ö%đ y x+O j&ø, 'EÀ 4

' ¼3[ F y&- T-l-¼,þ6Ô Ä ÖEE÷0;, ' šN# J T ã \?ù Ä

Ä V :>õ 9F2 f% yKÖE, ' d- x

Ä +X Ô • F Q - Ô ! ê ^ x

Ä 0- : Ô = ¼ ÔM» Ä

jÄî 7 ĘF2 f, '5\$ Ô Ö =F2 f, '5\$ Ô, 'Äî 7 J, 8\$ ÖE x Ì È+J

- ...

x ñB\$ >

x ñ F?ò/j ? .

x ñ j ( .

° \_ ò

Õ4ï Ê y

ê j+|M' ý ŒEB\$ > Ä n/j •(x \ Å

OÆN¥B\$ >

Aî5žN¥M'B\$ >

8ª ÃN¥M'B\$ >

× ñB\$ >  
 × ñ F?ò/j ? .



V n/j •(x \

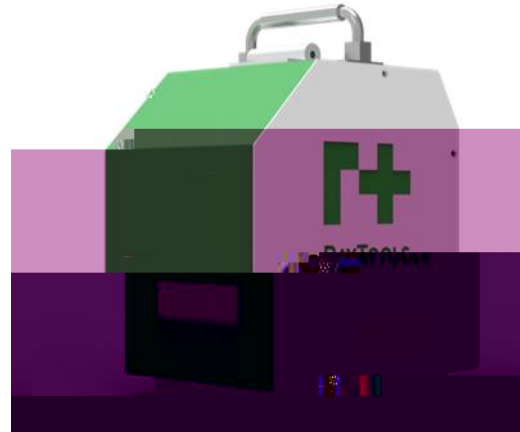

= V n/j •(x \

× ñ(©&é Ö

- ① 2î ö × f ÈF1 M2î ÖQ
- ② F1 M0c È È Y ¾ Î)àQ FO xQ CXGÿ, '%đ y': Ö j ÿ
- ③ G}5ž ` ü × 2î ö iG} 4/ý å
- ④ × f é ? J g xF2G} J/ý%đ y': Ö Đ Aî 7
- ⑤ P<sub>i</sub> × 0 f × ý Œ ï §
- ⑥ İ7-U€ ~ × C ¾ Î)à8 Ø F

× ñ j (.

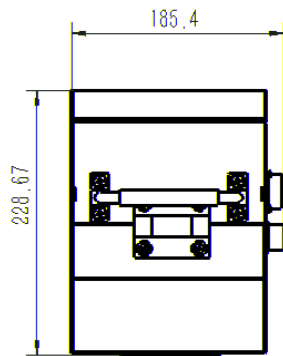

F?ò j (/j? .

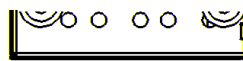
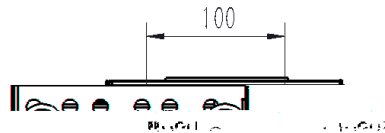

ÅG 1>ö „} /j? .

° \_ ò

x ñ É '				
x ñ 2« »	$j = V n/j \bullet$	$j = = V n/j \bullet$	$! \bullet F V n/j \bullet$	$! \bullet F = V n/j \bullet$
Ë+e?±"r				
0 WF1 MFO Ö				
F2+X': M-\$ ´	¶ ¶			
j (	K´ í Q			
GýGÿ	0			
79 â é A x f		•		•
Q Gÿ x f	•	•	•	
x f	•		•	
8 Ø í>• M	•		•	
ò N´Aî Ï7-	•			



Ö4i Ê y

8ß8Z , ' ? ÈJ,7JB\$ > ²; Ä j =(x \ Å

4i • Ö	J,7J ç ' Ê y	4i8ç
8Z lý d Ä Å		Tô5/8ç
8Z lý d Ä Å		; 8ç
8Z lý d Ä Å		8ç







③ = V n/j • !•F (x \ 8B8Z 4iJ,7J Ê yB\$ > ² ;

4i•Ö	J,7J ç'	Ê y	B\$ >
8Z œ d Ä Å			Ö 0 £+e\$Ä
8Z œ d Ä Å			

8Z œ d Ä Å

é A ' eH H bÄ

ê j+|M' ý OEBS\$ > Ä n/j •(x \ Ä

j ~ ê £ F1 M j ;, ' ê j+|M' 0 i 9 ZN¥M' È 6 [\_ ÌOÆN¥ Ð Ä

ÏA15ž Ð Ä Ì 8ª Ä Ð Ä Ì Ð Ä fF9 ]N¥M' & È • ... # xN¥M'F9 9JP

] >~B N¥M', ' 9JP n/j j4Ò8ç È ! % ZF9 ], 'N¥M' 9JP n/j jU 8ç Ä

OÆN¥B\$ >

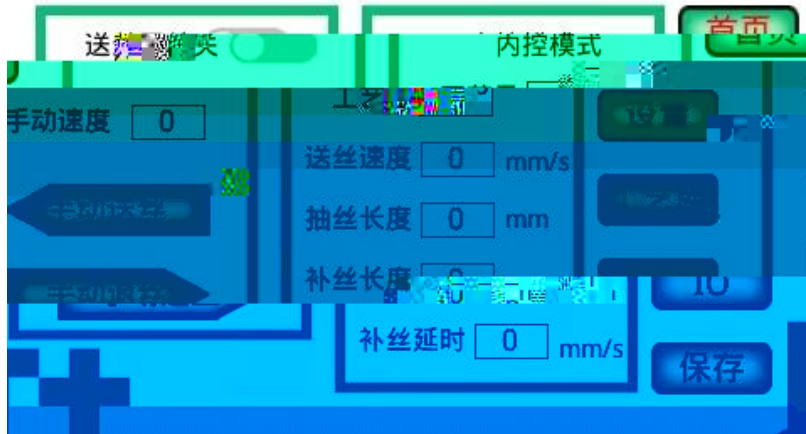

F1 M 0 £ Ö 0 \_ &F1 M j }7-F1 M Ä

{ ØFO Ö ÖB38² { ØF1 M Ä { ØF0 M 9JP ~+X, 'F >|FO Ö Ä Ä i

>0û £ 9 x Ä

{ ØF1 M Ö 9 ; 15 FOF1': M È @ 0 a OE!'F1 M

{ ØF0 M Ö 9 ; 15 FO í': M È @ 0 OE!' í': M Ä

8ª ' Ö 8ª Ä ], ' 8ª ' È ~ 0 j Z 8ª ' ÈF9 ÈB ?ñ 8ª ' )

' → ~ Ä

F1 MFO Ö Ö >~ f }F1 M, 'FO Ö Ä Ä i0ûPœ+O x È&é + ^ J° i, ' ò

^^ 8ª Ä ) Ä, '0; ¿ ' ] Ä

í MK~ Ö Ö >~ f } í M, 'K~ Ö Ä Ä i0ûPœ+O x È&é + ^ J° i, ' ò

^^ 8ª Ä ) Ä, '0; ¿ ' ] Ä

>• MK~ Ö Ö >~ f } >• M, 'K~ Ö Ä Ä i0ûPœ+O x È&é + ^ J° i, ' ò

^^ 8ª Ä ) Ä, '0; ¿ ' ] Ä

>• M & & Ö >~ f } í >• M & & Ä Ä i0ûPœ+O x È&é + ^ J° i, ' ò

ò ^^ 8ª Ä ) Ä, '0; ¿ ' ] Ä

Ai5žN¥M'B\$ >



FJf 7 ' ÖF1 M j x f Q ?Ai5ž È µ x j FJE÷ê j+|M' x f È F x j  
 '@ x f Ä  
 é A 7 ' ÖF1 M é AAi5ž Ä  
 F x 7- Ö 8a' x f Q ?Ai5ž È µ x jFJE÷ ê j+|M'F9 8a' È F x j  
 FJE÷ FG x f , ' é ?F9 8a' Ä  
 FO Ö Q ? Ö jFJE÷ Q Gy x f È jFJE÷ &é x f Ä  
 í> MFO Ö Ö í M Ä>• MFO ÖAi5ž Ä  
 !•F fGy Ö!yF1 !: M pM0?±, '79 â fGy Ä  
 = <!: M-\$ 'Ai5ž!•F fGy ò63>~ 2; Ö

!: M-\$ ' Ä Å	!•F fGy Ä Å

8a ÑÑM'B\$ >

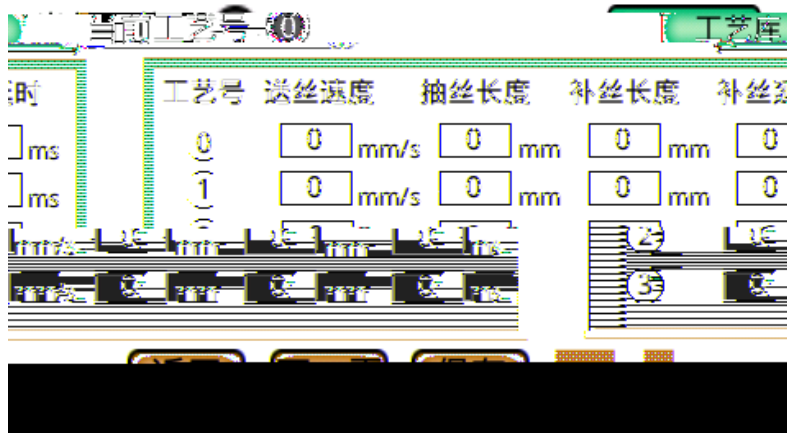

8a'	0; 2	0; 2	0; 2

8a')'—>~

8a' Ö 8a Ä; /ý 8a' Ä Å È!ý/ý 8a') Ä 0 ‡F1 M ò È  
 5 [F1 MFO Ö Ä í MK Ö Ä>• MK Ö Ä>• M & & Ä  
 F1 MFO Ö Ö >~F1 M, 'FO Ö Ä Ä i>&é+ ^} 9 x Å  
 í MK Ö Ö >~ í M, 'K Ö Ä Ä i>&é+ ^} 9 x Å  
 >• MK Ö Ö >~>• M, 'K Ö Ä Ä i>&é+ ^} 9 x Å  
 >• M & & Ö >~ í>• M & & Ä Ä i>&é+ ^} 9 x Å  
 f } 8a' Ö f } B3+X, ' 8a' Ä Ä XOÆN¥ JAî5ž Å

N¥M'B\$ >



F1 M ' Ö!“ h(æ 1 ; = Þ&ÿ ÈF >| õ å ; n/j j5/&ÿ Ä  
{ ØF1 M Ö!“ h(æ 1 ; = Þ&ÿ ÈF >| õ å ; n/j j5/&ÿ Ä  
{ ØF0 M Ö!“ h(æ 1 ; = Þ&ÿ ÈF >| õ å ; n/j j5/&ÿ Ä  
j = ÕA-EÃ • Ö f j = ÕA-J,7J f` ,FJ ' & Þ5/&ÿ ÄF1 M j \* u  
Lì & Þ 5/&ÿ Ä  
FO Ö Q ? é A Ö fFO Ö é AJ,7J f` ,FJ ' & Þ 5/&ÿ Ä Q ? ; -  
+X È fB ' Þ 5/&ÿ & F1 M é A J i Ä  
EÃ • Ö Î & n/j Q GÿEÃ \*+e » W ? Ä Q Gÿ ~ ) ÄF1 MFO Ö  
~  
uLìEÃ \* Ö f` j = ÕA- ' &3+5 JEÃ \*!" ' Ä

Lt ...

& ç .

Ä Å & ç . Ä V n/j •(x \ Å

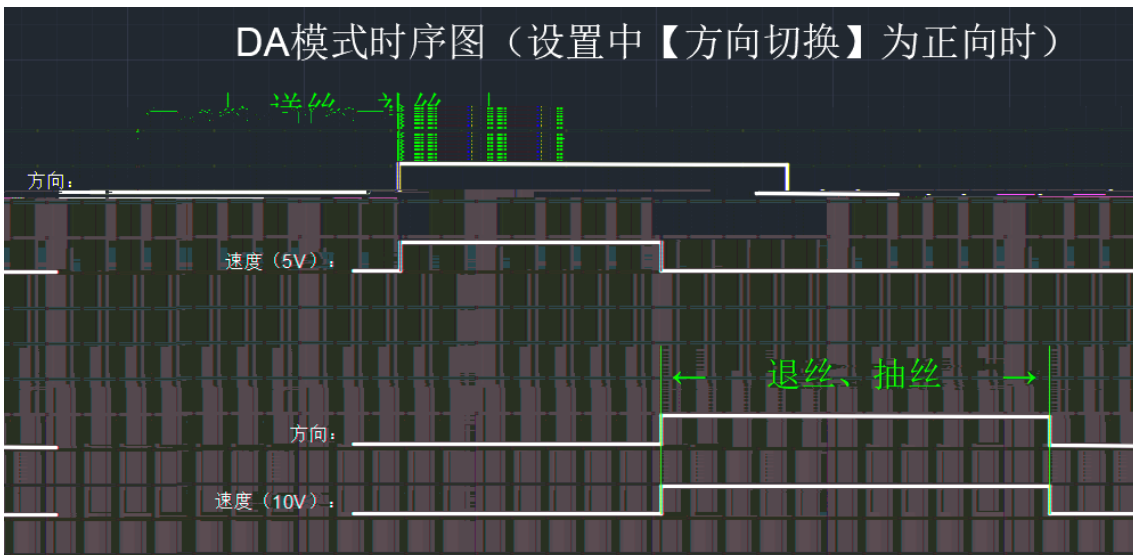
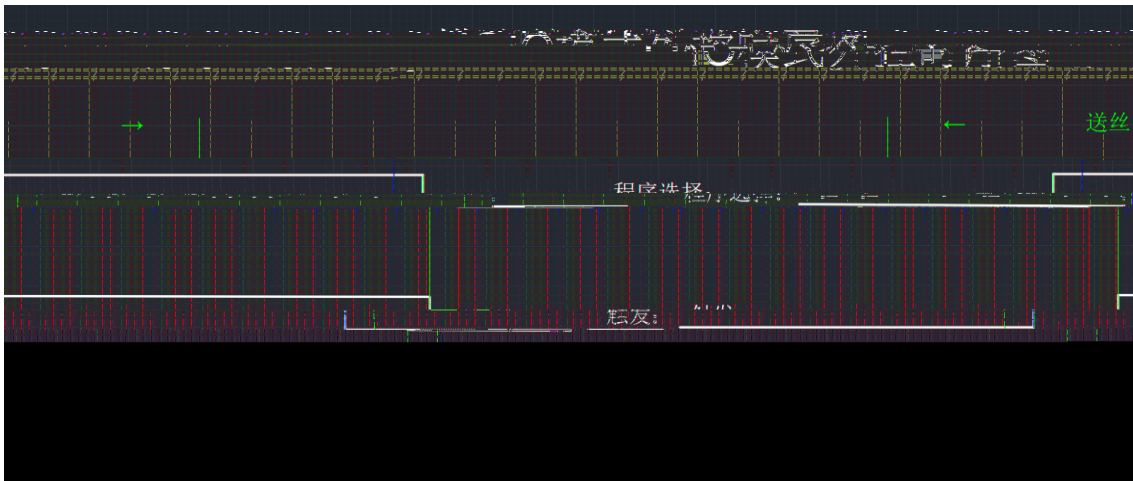
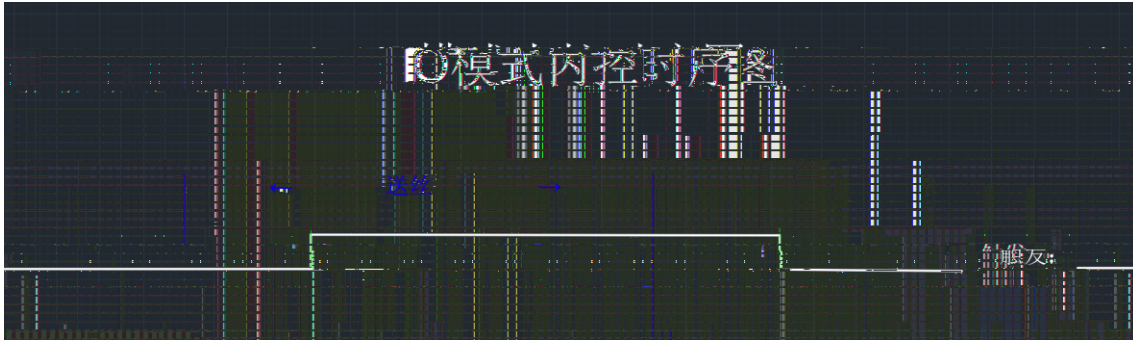

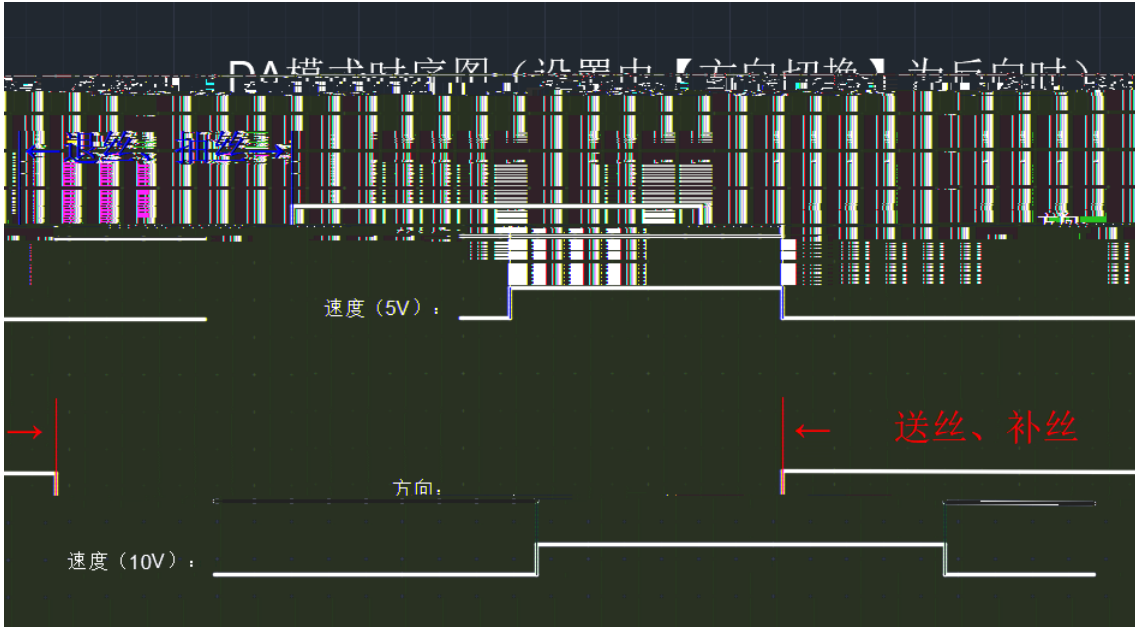

$$\dot{x} = V \cdot n / j \cdot \theta$$

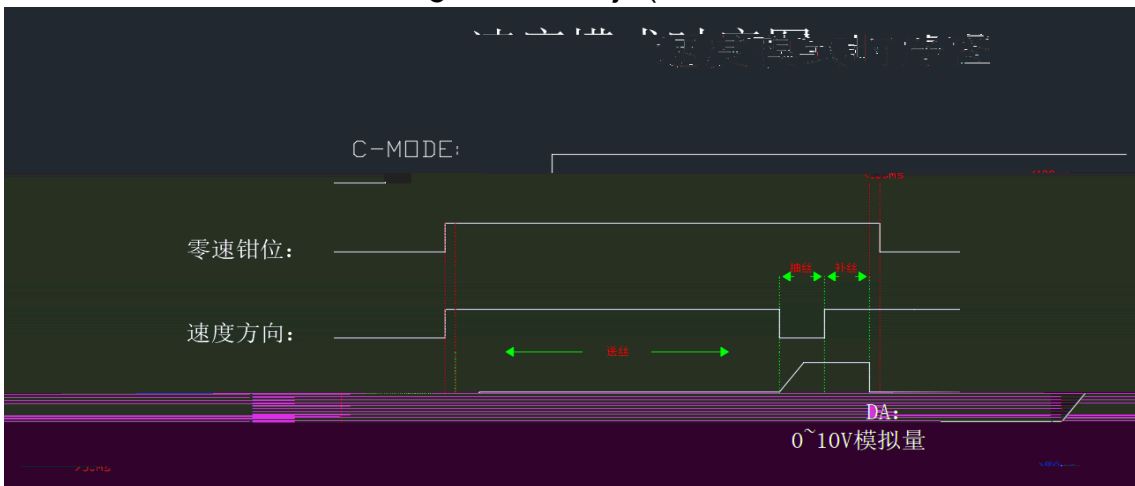

$$\dot{x} = V \cdot n / j \cdot \theta$$



j ~ uLÌAú Ý > 4\*6 é#

uLì)àB'	uLì 6 À Ĩ	@ ã é#
': M f%	Eα ~ Z »3WF1 MEž	B38²=ê ‡ ~': M>Û »3W
	': M-\$ ' ? ¼ MEž -\$!	\$ ' 8F2, ~': M
': M », Z\$!	F1 MEž » ĘE÷ W	B38²=ê4é M v ~': M 9 8F2 3W » Ę
F1 MFO Ö =0c F1 M =+u	': M X': M- Gü f5	ë¹ f5 G 6 ĘGý à5 M Ä
	F1 M1Ñ = iG} F/ •	\$ 'F1 M1Ñ
	F1 MEž = 8F2	\$ 'F1 MEž
	»3WEž » Ę =!“.ž	B3 - »3WEž » Ę
	F1 M+e j 2 h	\$ 'F1 M+e j
	Pi Ø 2 h	\$ 'Pi Ø k x f ~
	F1 M1Ñ e Ž	\$ ' F\$5*6F1 M1Ñ
	F1 M1Ñ _ "@ Ö ? ¼ Ö	6F1 M1Ñ mGÿ n-\$
	F1 M1Ñ T » > '	\$ 'F1 M1Ñ
ÿFO jF Eœ 2 ý	ÿFO j µG M& &/ • F ••	= F \$ '
F1 MEž ý AF Eœ	+e j+e Ò4i Ò4i =!“.ž	)B3 T i+e Ò4i
! uLì)àB'	= C ÿF	F1 ² æ5\$



## 机器人/平台送丝机 说明书

G} & F ' j (   
 Ä 0 Å F1 M1ÑÄ Å4ô & Ö j ( .

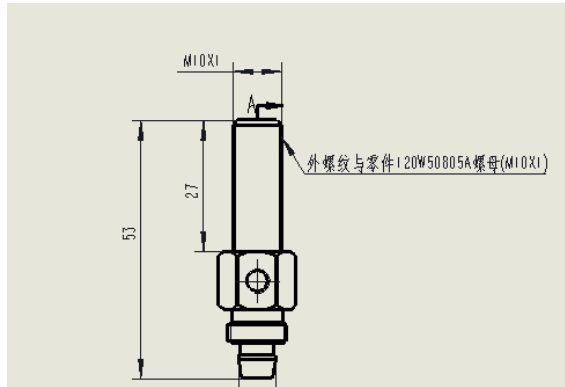

: . p/jjF1 M1Ñ4ô & , Ö j ( . È +X g -+X & M0 X 1>öEœ Ö & :AiAÑ 0 ZFJ ,,   
 +X ¾ \* È': M- EαÄF1 M1Ñ4ô &G÷+X Ð=êÿ > Û(w \* È È\*Ap 9 ¶ AiAÑFJ ,, Å   
 Ä ¼ Å': M- Eα Ö j (

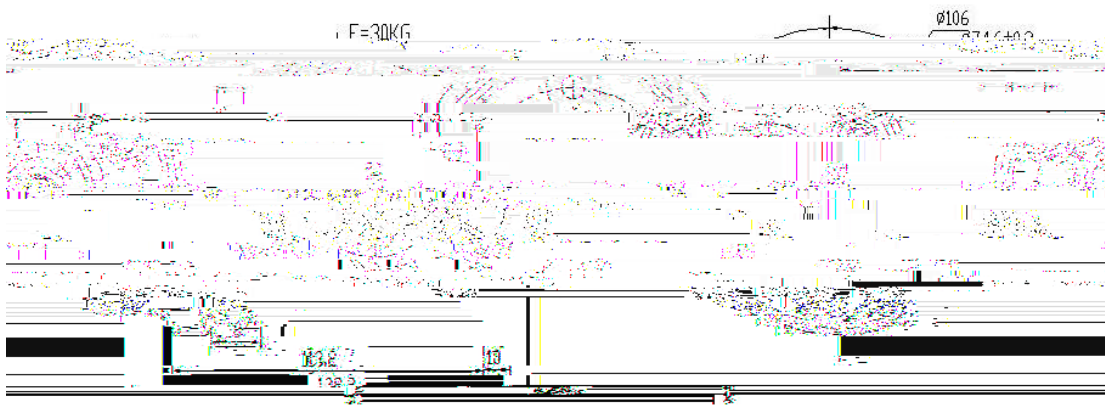

: . p/jj': M- Eα, Ö j ( . È +X g -+X & M0 X 1>öEœ Ö & :AiAÑ 9 ZFJ ,,+X   
 ¾ \* È': M- Eα Ä': M- EαG÷+X =ê C \* È È\*Ap 9 ¶ AiAÑFJ ,, Å